

LA-UR-73-1611

Conf-73111

Summary

A compact explosively-driven, metal-to-metal contact, solid dielectric switch has been developed for use as a low-resistance, $< 10\text{-}\mu\Omega$, low-inductance, $< 10\text{-nH}$, crowbar switch. A 100 milligram high-explosive charge is used to extrude a 0.090-in. plate through 0.040-in. polyethylene and achieve a hard current contact with a 0.625-in.-diameter die plate. The closure time, from the signal, which initiates the charge, to beginning of current rise in the switch, is $11.0\ \mu\text{sec} \pm 0.3\ \mu\text{sec}$. In crowbar application the switch has carried 180-330 kA which decays with a $1/e$ time of $\approx 1.2\ \text{msec}$.

Design Development

One of the experimental machines in LASL fusion research, known as the "Toroidal Z-Finch" device, required the use of a fast-acting, metal-to-metal type switch for use in a low-inductance crowbar application. The space available in the machine geometry where these switches were to be installed was extremely minimal; consequently, these switches had to be designed as small self-contained units, quite unsimilar to a previously-used exploding foil switch.¹ The foil switches, while being desirable for some applications, require, among other features, large and elaborate clamping mechanisms, complex individual capacitance discharge systems, and general environmental necessities such that their use in our application seemed impractical. Our attention was therefore directed toward alternate energy sources to perform the switching action, i.e. to the use of high explosives. It was observed that while the exploding foil switch does not use a powder charge per se, it nonetheless makes use of expanding gases, not too unlike a powder discharge, to perform its function. In this sense only the two switching actions may be considered similar. It was also observed that the use of high explosives would not only provide us environmental flexibility, but would also offer a much wider range of explosive characteristics from which to choose. For example, the weight and type of powder charge could be varied and selected for the desired speed of burning and energy potential. Shaped charges could be used depending upon whether more penetration of the discharge was considered necessary (a la "Monroe Jet" principal). These were a few of the factors that led to the development and ultimate use of the detonator switch about to be discussed.

The basic action required in switches of this type, whether foil or detonator, involves the deformation of metal. This deformation, however, must be done in an extremely sophisticated manner and the one best versed in this field is the explosive metal-forming industry. Considerable literature is available on the subject of explosive metal forming and we found that the techniques applied here could be almost directly applied to our own requirements. Further study in this field also revealed that of all the energy sources for high-velocity forming, the use of high explosives is perhaps the most versatile.² In the light of the explosive-forming business then, we have what is called a typical explosive working system. In order for such a system to operate successfully it must embody the following features: (1) an explosive charge; (2) an energy transmittal medium; (3) a die plate; and (4) a work piece.

Within our frame of reference (see Fig. 1) explosive charge is a Type RP-2 detonator manufactured by Reynolds Industries of California. It is of the miniature variety, 0.200-in. diameter and approx 0.450-in. long. There are two explosive charges contained in this unit weighing approximately 0.4 m. The first charge is low-density PETN located adjacent the gold bridge wire initiator. This type charge burns extremely fast, which in turn ignites a high-density charge of tetryl which acts as a high energy booster. The manufacturer of these detonators provides a rigidly controlled crystallization procedure of the explosive and loading operation. Charge is controlled through consistency of crystallization and precision weighing. The result is a detonator with a transmission time simultaneity of $\pm 25\ \text{ns}$. "Energy transfer medium" is a material used not only to transmit a fast uniform shock wave, but also act as an efficient coupling agent. The most efficient material for such purposes would be some incompressible liquid such as water or oil. Both these materials, though ideal, would be difficult to contain in our particular geometry without fairly elaborate sealing methods. Hence, our second choice material, paraffin, is currently in use. The paraffin is premolded to fit the conical void between the detonator and the driven plate, or driven plate as we call it (Fig. 1). The "die plate" in our system is in the shape of a washer made of 6061-T6 aluminum alloy, and although this is replaced after each shot, its use performs an important dual function. It not only "shapes" the leading edge of the driven plate, but it also acts as a current joint edge. The "work piece" in our system is a piece of 1100-O aluminum and is deformed by the expanding gases in such a manner that the "die plate" and "driven plate" are intimately forced together. Figure 2 shows the before and after explosion condition. An explanation of the explosive action is as follows: the detonator is assembled in the breech block with its open end extending within the conical taper section. The pre-molded paraffin plug which acts as the energy transfer medium is then pressed into the taper section. It is extremely important that the front end of the detonator is actually imbedded within the paraffin so that the coupling effect between the explosion and the driven plate is thus more fully assured. The rear of the detonator is closed off with a steel backup plug (see Fig. 1). This slug is appropriately slotted to provide passage for the bridge wire leads, but it also prevents successive loss of explosive pressure out the back. When the detonator is fired, the incident shock wave travels in a spherical manner through the transfer-medium material. A uniform pressure front then exerts itself over the area of driven plate as limited by the base of the conical taper section. It is important here to have a thin film of grease between the transmitting medium and driven plate to more effectively couple the shock front and drive the plate. The O-ring, immediately outside this area, serves to contain the explosion and prevent any lateral pressure loss. As the uniform pressure wave hits the surface of the driven plate, bending and extruding action takes place forcing the plate material first against the anvil piece, where current contact is initially made, then into the die plate where it becomes imbedded in the annulus between the die-plate washer and the anvil. This action causes the polyethylene insulator in the process and act causes it to flow out-of-the-way and ahead of the

BLANK PAGE

1-1611

Summary

compact explosively-driven, metal-to-metal con-
solid dielectric switch has been developed for
a low-resistance, $< 10\text{-}\mu\Omega$, low-inductance,
crowbar switch. A 100 milligram high-explosive
is used to extrude a 0.090-in. plate through
n. polyethylene and achieve a hard current con-
th a 0.625-in.-diameter die plate. The closure
rom the signal, which initiates the charge, to
ng of current rise in the switch, is 11.0 μsec
sec. In crowbar application the switch has car-
D-330 kA which decays with a 1/e time of ≈ 1.2

Design Development

of the experimental machines in LASL fusion re-
known as the "Toroidal Z-Pinch" device,
l the use of a fast-acting, metal-to-metal type
for use in a low-inductance crowbar application.
is available in the machine geometry where these
were to be installed was extremely minimal;
ntly, these switches had to be designed as small
tained units, quite unsimilar to a previously-
lodging foil switch.¹ The foil switches, while
sirable for some applications, require, among
atures, large and elaborate clamping mechanisms,
individual capacitance discharge systems, and
environmental necessities such that their use
application seemed impractical. Our attention
efore directed toward alternate energy sources
rm the switching action, i.e. to the use of high
es. It was observed that while the exploding
tch does not use a powder charge per se, it
ess makes use of expanding gases, not too unlike
discharge, to perform its function. In this
ly the two switching actions may be considered

It was also observed that the use of high ex-
would not only provide us environmental flexi-
but would also offer a much wider range of ex-
characteristics from which to choose. For ex-
he weight and type of powder charge could be
nd selected for the desired speed of burning
gy potential. Shaped charges could be used de-
upon whether more penetration of the discharge
idered necessary (a la "Monroe Jet" principal).
re a few of the factors that led to the develop-
ultimate use of the detonator switch about to
used.

basic action required in switches of this type,
foil or detonator, involves the deformation of
This deformation, however, must be done in an
y sophisticated manner and the one best versed
field is the explosive metal-forming industry.
able literature is available on the subject of
a metal forming and we found that the techniques
ere could be almost directly applied to our own
nts. Further study in this field also revealed
all the energy sources for high-velocity forming,
of high explosives is perhaps the most versa-
In the light of the explosive-forming business
have what is called a typical explosive work-
m. In order for such a system to operate suc-
it must embody the following features: (1) an
charge; (2) an energy transmittal medium; (3)
ite; and (4) a work piece.

Within our frame of reference (see Fig. 1) the ex-
plosive charge is a Type RP-2 detonator manufactured by
Reynolds Industries of California. It is of the sub-
miniature variety, 0.200-in. diameter and approximatel
0.450-in. long. There are two explosive charges con-
tained in this unit weighing approximately 64 mg. The
first charge is low-density PETN located adjacent to
the gold bridge wire initiator. This type charge is
extremely fast burning, which in turn ignites a second
high-density charge of tetryl which acts as a high-
energy booster. The manufacturer of these detonators
provides a rigidly controlled crystallization process
of the explosive and loading operation. Charge density
is controlled through consistency of crystalline struc-
ture and precision weighing. The result is a detonator
with a transmission time simultaniety of ± 25 nsec. The
"energy transfer medium" is a material used not only to
transmit a fast uniform shock wave, but also act as an
efficient coupling agent. The most efficient material
for such purposes would be some incompressible liquid
such as water or oil. Both these materials, though
ideal, would be difficult to contain in our particular
geometry without fairly elaborate sealing methods.
Hence, our second choice material, paraffin, is the
agent currently in use. The paraffin is premolded to
fit the conical void between the detonator and the work
piece, or driven plate as we call it (Fig. 1). The
"die plate" in our system is in the shape of a washer
made of 6061-16 aluminum alloy, and although this piece
is replaced after each shot, its use performs an impor-
tant dual function. It not only "shapes" the deforma-
tion of the driven plate, but it also acts as a suitable
current joint edge. The "work piece" in our system is
a piece of 1100-0 aluminum and is deformed by the ex-
panding gases in such a manner that the "die plate" and
"driven plate" are intimately forced together. Figure
2 shows the before and after explosion conditions. An
explanation of the explosive action is as follows. The
detonator is assembled in the breech block with its
open end extending within the conical taper section.
The pre-molded paraffin plug which acts as the trans-
fer medium is then pressed into the taper section. It
is extremely important that the front end of the deto-
nator is actually imbedded within the paraffin since
the coupling effect between the explosion and the paraf-
fin is thus more fully assured. The rear of the detona-
tor is closed off with a steel backup slug (see Fig. 1).
This slug is appropriately slotted to provide passage
for the bridge wire leads, but it also prevents an ex-
cessive loss of explosive pressure out the back. When
the detonator is fired, the incident shock wave expands
in a spherical manner through the transfer-medium mate-
rial. A uniform pressure front then exerts itself on
the area of driven plate as limited by the base area o
the conical taper section. It is important here to ha
a thin film of grease between the transmitting medium
and driven plate to more effectively couple the shock
front and drive the plate. The O-ring, immediately
outside this area, serves to contain the explosive for
and prevent any lateral pressure loss. As the uniform
pressure wave hits the surface of the driven plate, a
bending and extruding action takes place forcing the
plate material first against the anvil piece, where
current contact is initially made, then into the die
plate where it becomes imbedded in the annulus between
the die-plate washer and the anvil. This action shears
the polyethylene insulator in the process and actually
causes it to flow out-of-the-way and ahead of the

UNCLASSIFIED

UNCLASSIFIED

advancing metal of the driven plate. The anvil, made of hardened steel and opened with a through-hole, not only provides for the essential venting of the die area, but also acts as a bumper which stops the driven-plate material in the restrictive fashion as shown, after initial current contact. The metal-to-metal contact thus made is extremely tight, comparable perhaps to a "press-fit" condition found between various machine elements. This contact completes the switching action between the positive and negative potentials as shown in Fig. 2.

When experimentation was originally started on the development of this detonator switch, some of the initial tests conducted were influenced to some degree by prior design criteria which had been used on the exploding foil switches.³ It soon became apparent that this influence, though not without merit, was just not applicable to detonator use. Consequently a new set of parameters had to be established and new lore developed.

Where the most efficient die geometry used in the foil switch was a slot, it was not so with the detonator. The slot configuration did appear somewhat faster in closing time, but the end effect, or the part at the end of the slot, did not fully close and presented a very marginal current contact and was found to cause arcing when the current was switched. This and other limitations of the slot geometry led to the adoption of the circle as a more ideal die-plate geometry where the circle's circumference became the effective length of current-carrying surface. Since the detonator shock wave expands in a spherical manner, the constraint of the circular hole geometry thus became ideal for assuring a uniform current contact on thin surface.

Additional lore was established after several shots were fired with the detonator in direct contact with the driven plate. This procedure, though effective with foil switches, was disastrous for the detonator switch. We simply blew a hole clear through the driven plate and disintegrated the very material we needed to perform the switching action. After further study of explosive-forming references, we concluded that "contact operations" would not achieve our ends but rather the application of "stand-off" techniques would be more effective.

The terms "contact" and "stand-off" operations are simply the two main divisions used by the explosive metal-forming industry. "Contact" operations are those where the explosive charge is located directly, and in contact with, the work piece. The "stand-off" operations are those where the charge is placed some distance away from the work piece and the optimum distance is some junction of the diameter of explosive charge. The most desirable condition in our case is with the front end of the detonator at 0.100 in. from the driven plate, together with a 45° angle in the recess. This combination results in the most suitable deformation of the switch plate.

First Design

Due to space limitation as mentioned previously, our first design was to incorporate this switch with a through bolt being used to hold the transmission lines together. Such an arrangement is shown in Fig. 3 where the switch was designed in a coaxial manner and as can be seen, it includes the necessary plate constraints as well as the required switching characteristics. While the design was found to be workable, subsequent measurements showed its inductance as too excessive to warrant further development.

The calculated inductance, assuming the switch to be made up of small "infinite" (Fig. 4) sections, was 5.7 nH. The inductance measured was ≈ 37 nH.

With the test circuit (Fig. 5) the switch carried up to ≈ 125 kA with a 1/e decay of 600 μ sec with negligible arcing. The closure time is defined as the time

from the beginning of current to the detonator bridge wire to the beginning of current in the switch, and was 12 μ sec ± 0.5 μ sec. Figure 6 shows a current trace of the crowbar current. The peak current in the crowbar was 277 kA and the current being switched in the load was 170 kA with an 1/e decay time of 600 μ sec.

In the ideal case where the crowbar is assumed to have no inductance and resistive effects are neglected the peak crowbar current is exactly double the current in the load. In the actual situation an accurate description of the switch capability includes two currents (1) the current in the load at the time of crowbar switch closure, and (2) the peak current the crowbar switch carries. Furthermore, the decay time of the current in the load is also an important parameter called the 1/e decay time or L/R time where L and R are the inductance and resistance respectively of the crowbar switch and load-circuit loop. Still referring to Fig. 6, notice that at about 300 μ sec there is a discontinuity. This is presumably the point at which the switch began to burn. The 170 kA was much less than the expected 300 kA we were hoping to achieve. Although this was discouraging, it did provide very valuable information as to the maximum energy density we could hope to achieve with this switch when working in the range of 1/e decay times of 1 msec. Further, it provided the needed information to extrapolate the switch design and meet the switch requirements.

For the time of interest, i.e., up to the point the switch starts to burn, 300 μ sec, the current is of the form

$$I = I_0 e^{-R/L t} - I_0 \cos \omega t e^{-R/L t}$$

Where, Fig. 5,

$$L/R = \frac{L_p + L_{cb}}{R_2}$$

ω = ringing frequency of capacitor bank through L_p ,

$$l/r = \frac{L_1 + L_{Ts} + L_p}{R_1}$$

and

$$I_0 = \text{maximum average crowbar current.}$$

Before the equation could be plotted, a determination of the four parameters, I_0 , ω , L/R , l/r , had to be made. By careful examination of the oscillogram, ω was measured. Between about 200 μ sec and 300 μ sec, the second term is absent from the equation due to ignition cut-off. By taking careful measurements of relative current amplitude and time at two different times, L/R could be found by the following equation:

$$L/R = \frac{t_2 - t_1}{\ln(I_2/I_1)}$$

This equation assumes R, the resistance, in the crowbar loop to be constant. This is not true because of the skin effect, however, it is a reasonable approximation and for the purpose of this calculation will be assumed. Since the current was measured with a calibrated Rogowski loop, I_0 could be determined. The constant l/r was determined by fitting the equation to the data. We can now calculate the total energy dissipated in the switch up to the time it started to burn. Using

$$I_0 = 158.5 \text{ kA}$$

$$\omega = 1.84 \times 10^5$$

$$L/R = 1.67 \times 10^3$$

and

$$r/l = 1.72 \times 10^5$$

we have:

$$E = \int_0^t I^2 R_s dt$$

$$= \int_0^{300 \mu\text{sec}} \left(I_0 e^{-R/L t} - I_0 \cos \omega t e^{-r/l t} \right)^2 R_s dt$$

$$= \int_0^{300 \mu\text{sec}} \left(I_0^2 e^{-2 R/L t} - 2 I_0^2 \cos \omega t e^{-(R/L - r/l) t} + I_0^2 \cos^2 \omega t e^{-2 r/l t} \right) R_s dt$$

Note: When the energy is actually calculated, one finds that the last two terms actually contribute less than .5% to the total energy, when $t = \infty$.

$$E = 50 \text{ joules, assumes } R_s = 10 \mu\Omega$$

$$\text{Energy density} = 12.5 \text{ joules/cm}$$

Second Design

The foregoing calculations served as a basis for second and much improved design. This concept, known as the transmission-plate design and the one currently in use, is shown in Fig. 7. As will be noted, this arrangement is without the through-bolt constraint feature, and though the bolt omission allows some plate deflection in this area, due to magnetic field pressure, it was not considered great enough to cause concern. By omitting the bolt, we were able to build the switch directly into the transmission lines as shown. Several additional features were also introduced at this time. By changing the thickness of the driven plate from .062 in. to 0.090 in., its penetration into the die plate was greatly improved, thus doubling the energy dissipation of this joint. The diameter of the hole in the die plate was enlarged by 20%, thus increasing its current carrying capability. Additional venting of the anvil and die-plate areas further shortened the effective closure time by eliminating excessive back pressure. Difficulties with the breech design led to its further refinement through the study and use of various materials. Cold rolled steel was first used but erosion and compaction of this material, due to the detonator explosion, increased the hole size or clearance around the detonator to such an extent that succeeding shots resulted in faulty reproducibility. Ingoten alloy and tool steel were tried, but severe cracking and continued erosion was observed. The material presently in use is AISI 4340 steel, heat treated to approximately 250,000 psi. It appears to be strong enough and yet not too brittle to contain the explosive pressure without cracking. The erosion problem was eliminated by using a small steel sleeve fitted around the detonator body. When the detonator fired, the erosion occurred on the inside of the sleeve only. By using a new sleeve on each shot the breech material remains essentially unaffected.

Further refinements that were incorporated include retracting constrictor yokes for both breech block and anvil side, thus allowing rapid replacement and reassembly of parts. Suitable dies were designed to economically form the driven-plate pieces as well as dies for casting the conical paraffin slug. Electrical contacts to the detonator lead wires were simplified, requiring only "banana plug" type connections to the breech assemblies.

Tests were performed on this design and the following conditions were observed. A current of 280 kA in the load was crowbarred with subsequent $L/R \approx 1.2$ msec with no burning of the contact points, Fig. 8.

Switch Inductance. Referring to Fig. 5, careful measurement of the period of the circuit ringing with L_1 only and $L_1 + L_{TS} + L_p$ only, with a calculation of L_{TS} , L_p was determined to be

$$L_p = 48 \text{ nH}$$

L_{CB} could be determined from the ripple on the crowbar current signal. Using the following equation and Fig. 9,

$$\frac{1/2 B}{A} = \frac{L_{CB}}{L_p}$$

The inductance of the crowbar and transmission lines was determined to be 7.2 nH. Since much of the inductance is in the transmission lines, the inductance of the crowbar must be on the order of

$$L_{CB} \approx 2 - 3 \text{ nH}$$

Switch Resistance. A high resistance was connected directly across the transmission plates and the voltage was measured with a Pearson current transformer. The bottom trace, Fig. 10, shows the voltage across the switch. Notice that at about 200 μsec , $V = 0$ at this time, and;

$$LI = IR$$

from the crowbar current trace about I was estimated to be 1.9×10^8 A/sec. At this time $I = 1.7 \times 10^5$ A. Using these figures and 2.5×10^{-9} H for the inductance,

$$R_s = 2.8 \mu\Omega$$

High-Voltage Hold Off. The in-plate transmission-line switch was assembled on a test stand and connected to a 50-kV capacitor. The capacitor was charged to various voltages, the assembly was pulsed to a maximum of 42 kV and the switch fired. Each pulse the closure time was measured to determine the effect of the voltage on closing time of the switch. Figure 11, top trace, shows the high-voltage pulse being switched some 9 μsec after it comes on. The bottom trace shows the current in the detonator bridge wire. On the low-voltage, high-current tests the average closure time was $t_c = 11 \mu\text{sec} \pm 0.3 \mu\text{sec}$. With 42 kV on the switch, the closure time is affected and the closure time is shortened 2.0 μsec , Fig. 12.

Conclusions

A compact metal-contact crowbar switch that is activated by a small explosive charge (~ 100 mg HE) has been developed. The switch has a closure time of $11.0 \mu\text{sec} \pm 0.3 \mu\text{sec}$, with 0.040 in. polyethylene insulation. Both the resistance and inductance are very low, $R < 3 \mu\Omega$, and $L < 3$ nH. The switch will crowbar a load current of 330 kA with a $1/e$ decay time of 1.2 msec. Due to the current doubling effect of crowbaring, the switch carries ≈ 600 kA on a short-time scale, several tens of μsec . Although the switch-closure time is slightly affected when it has high voltage on it, in crowbar use the voltage is small at switch closure. In the case of ZT-1, a magnetic energy-storage system imposes a fast, high-voltage spike (60-80 kV; few tenths of a μsec long) on a load followed by a fast-rising current (rise time of 0.1 μsec) which rings with a sort of cosine wave (the period is 40-60 μsec). The crowbar switch was ideal in this case because it enabled crowbar

of the load current 3.0 μ sec after the high-voltage spike, still within 95% of peak current.

This switch has been developed using but a single detonator. It is not inconceivable, however, that considerably higher currents could be switched simply by using two or more similar detonators in the same systems and firing them in parallel. It is also possible to use other detonators having higher and faster powder charges, thus larger current contact areas could be effectively used.

While designed primarily as a crowbar switch, the detonator-switching action has also been used in other switch functions where low resistance and low inductance is a requirement.

References

1. D. L. Call, "Engineering Problems of Fusion Research," Los Alamos Scientific Laboratory report LA-4250, (1969).
2. "High Velocity Forming of Metals," A.S.T.M., (1964).
3. J. A. Phillips, "Proposal for a Shock-Heated Toroidal Z-Pinch Experiment," Los Alamos Scientific Laboratory report LA-4352, (1969).

WASH. STATE

7 1/3 x 9 15/16 PRINT SURFACE FOR 3 1/2 x 11 PAGE

TO 753 COPY

Captions

- Fig. 1 Schematic of main switch features.
- Fig. 2 Switch conditions before and after detonation.
- Fig. 3 Throughbolt assembly.
- Fig. 4 Inductance calculation schematic.
- Fig. 5 Current test circuit.
- Fig. 6 Crowbar current trace, throughbolt design.
- Fig. 7 Transmission plate design.
- Fig. 8 Crowbar current transmission plate design.
- Fig. 9 Effect of source inductance on crowbar current ripple.
- Fig. 10 Measurements for calculation of transmission plate inductance.
- Fig. 11 Switching a high-voltage pulse.
- Fig. 12 Closure time v.s. switch voltage.

NOTICE

This report was prepared as an account of work sponsored by the United States Government. Neither the United States nor the United States Atomic Energy Commission, nor any of their employees, nor any of their contractors, subcontractors, or their employees, makes any warranty, express or implied, or assumes any legal liability or responsibility for the accuracy, completeness or usefulness of any information, apparatus, product or process disclosed, or represents that its use would not infringe privately owned rights.

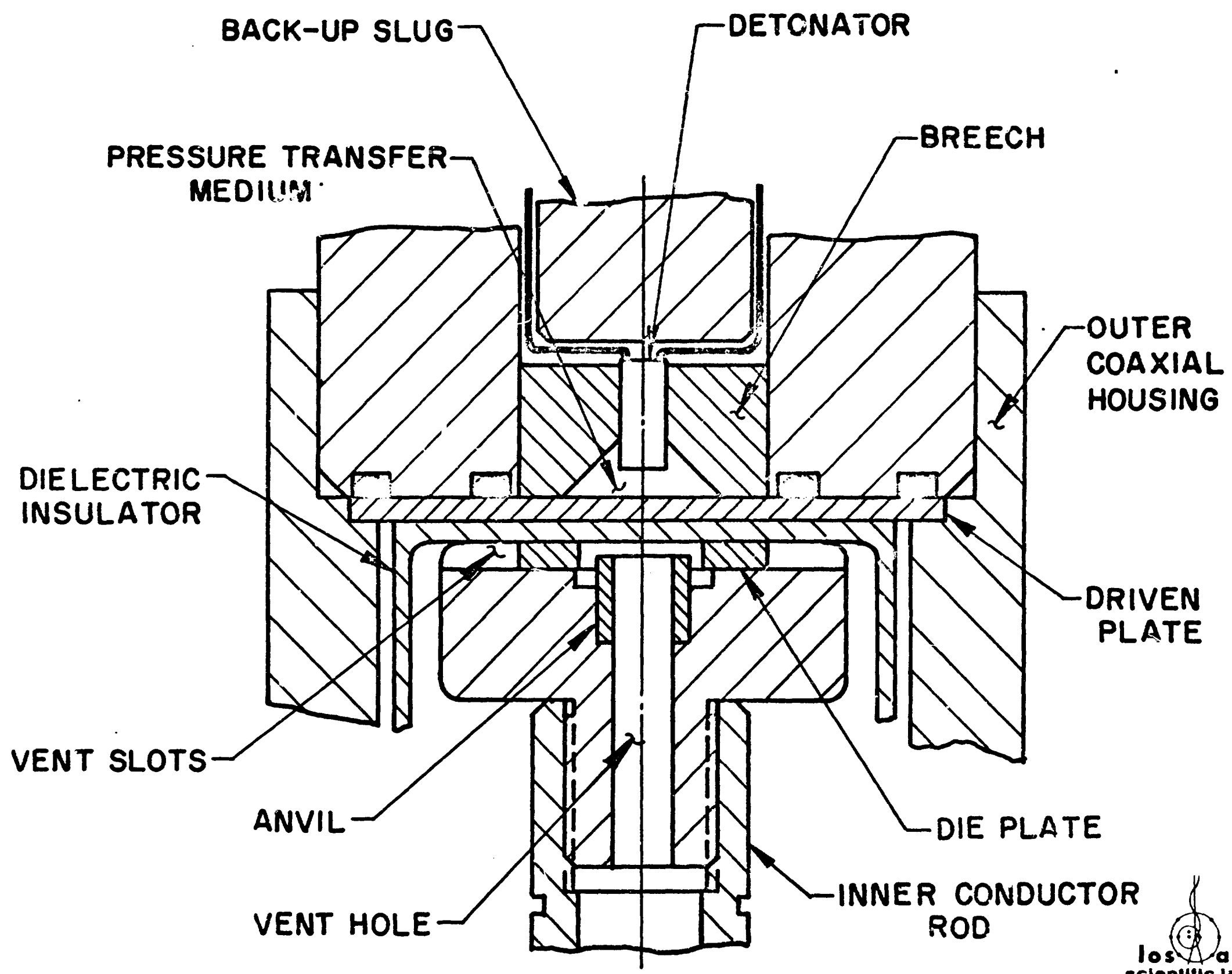
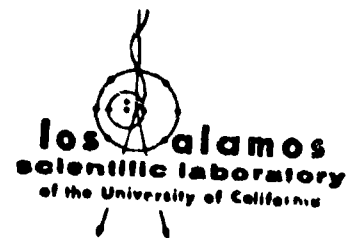
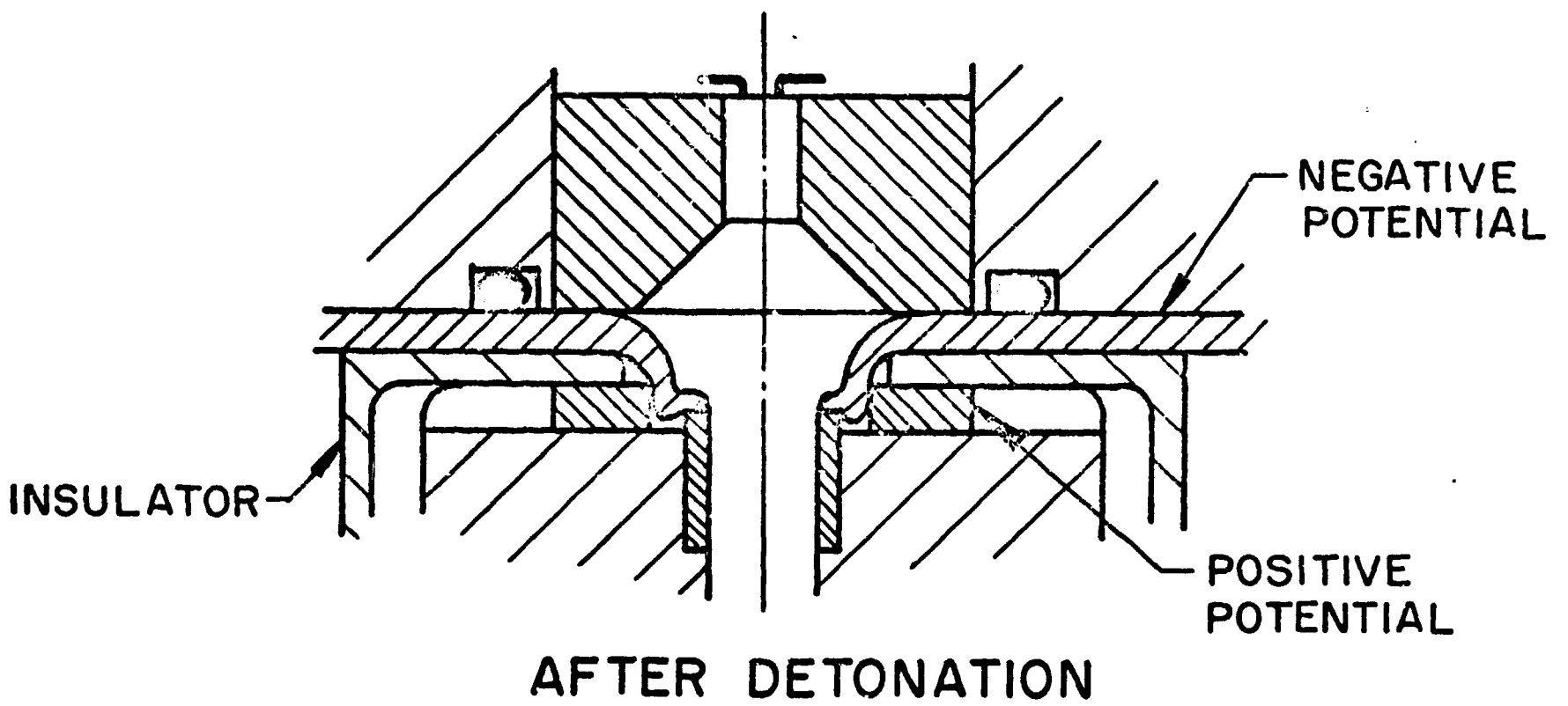
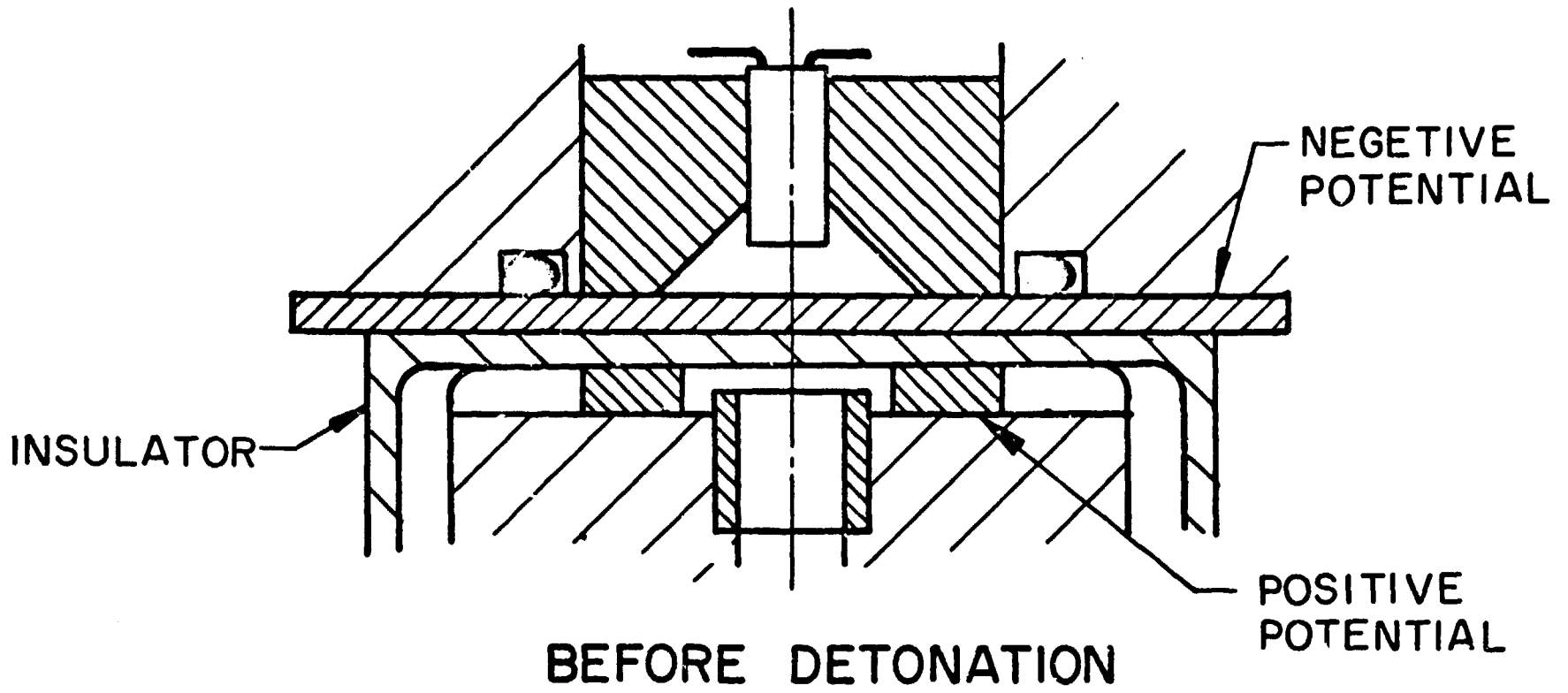
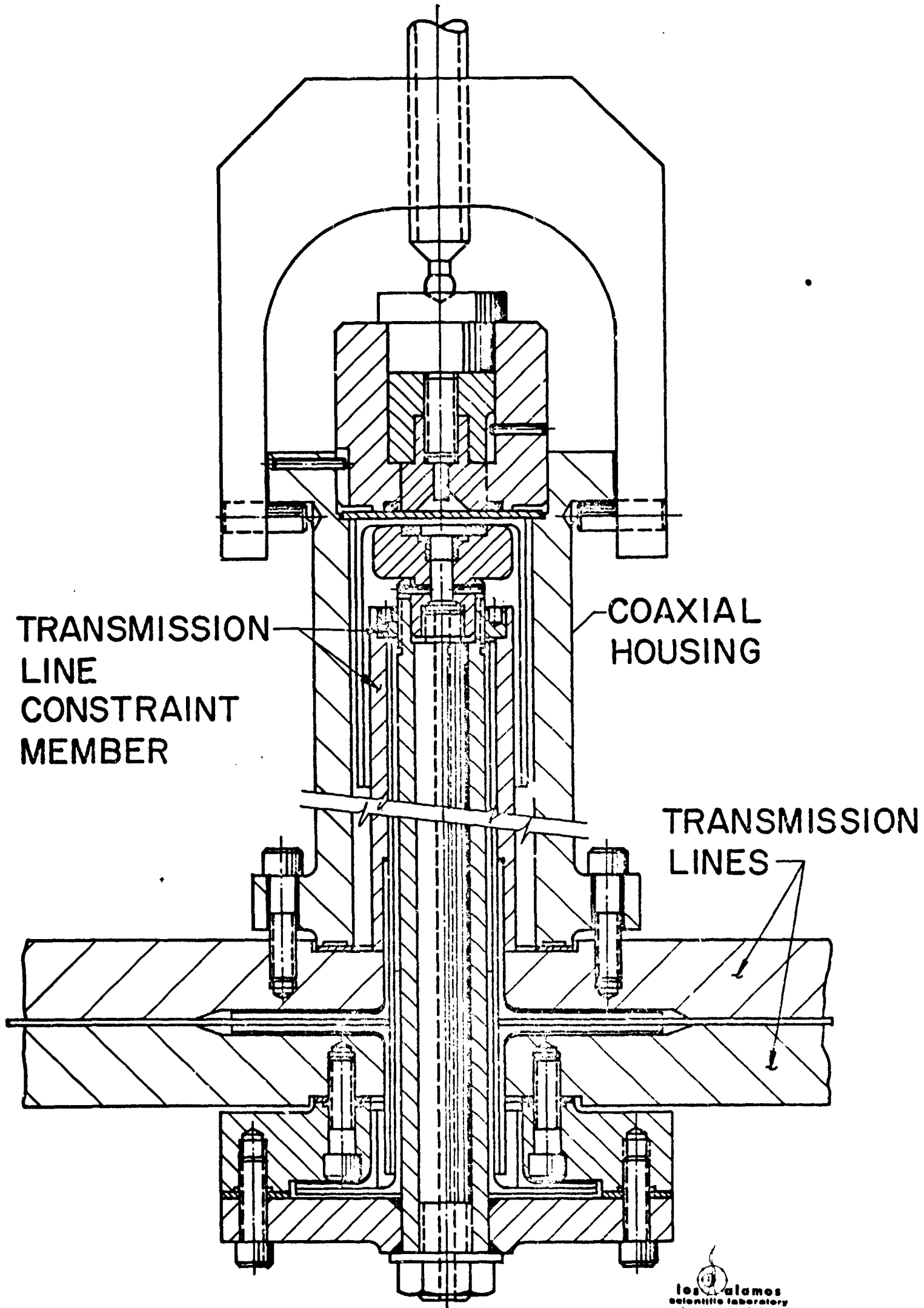

Fig. 1



LA-37-AEC-OFFICIAL

Fig 2



LASL-AEC-OFFICIAL

LASL-AEC-OFFICIAL



Fig 3

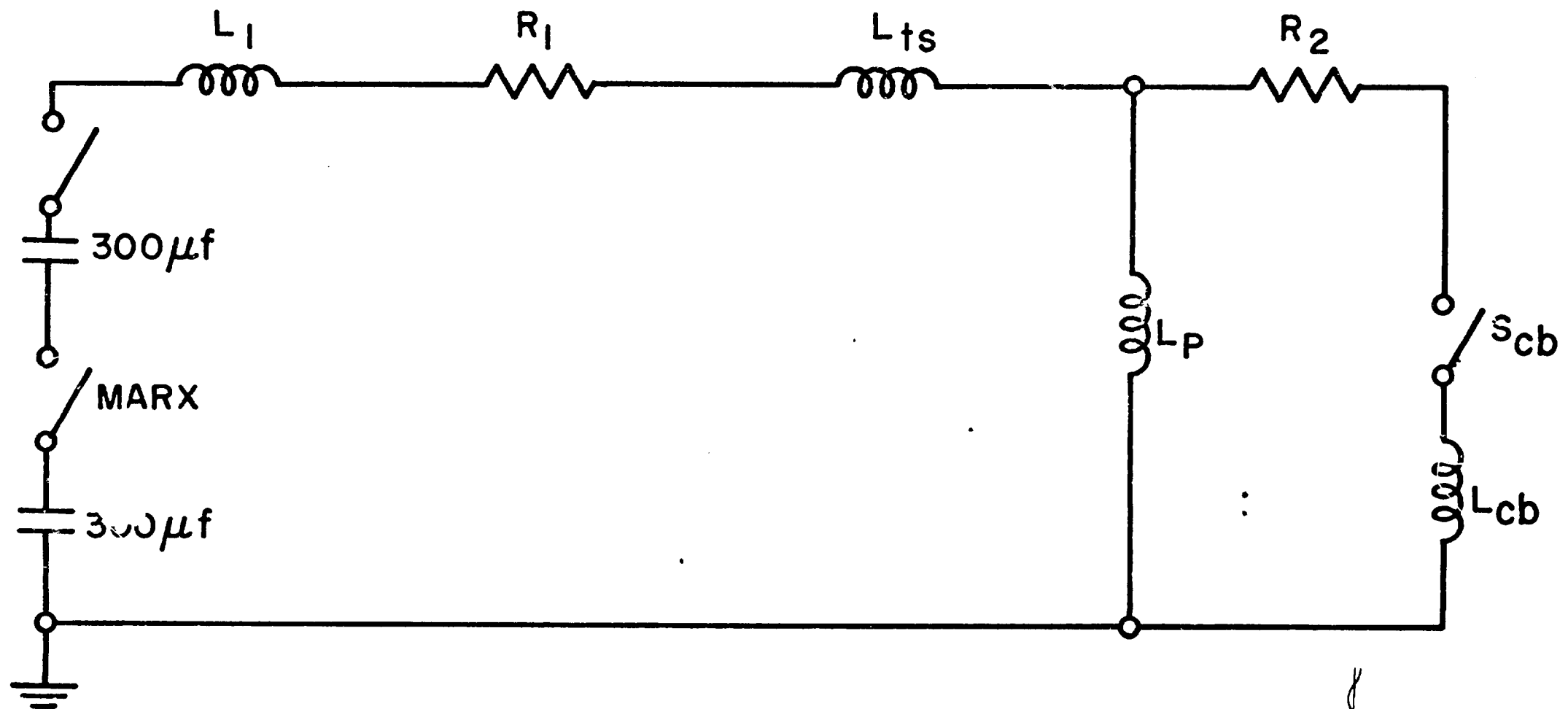

- L_1 SOURCE INDUCTANCE
- L_{ts} TRANSMISSION LINE INDUCTANCE
- L_p ALUMINUM PINCH INDUCTANCE
- L_{cb} CROWBAR INDUCTANCE
- R_1 SOURCE RESISTANCE
- R_2 PINCH AND CROWBAR RESISTANCE



Fig 4

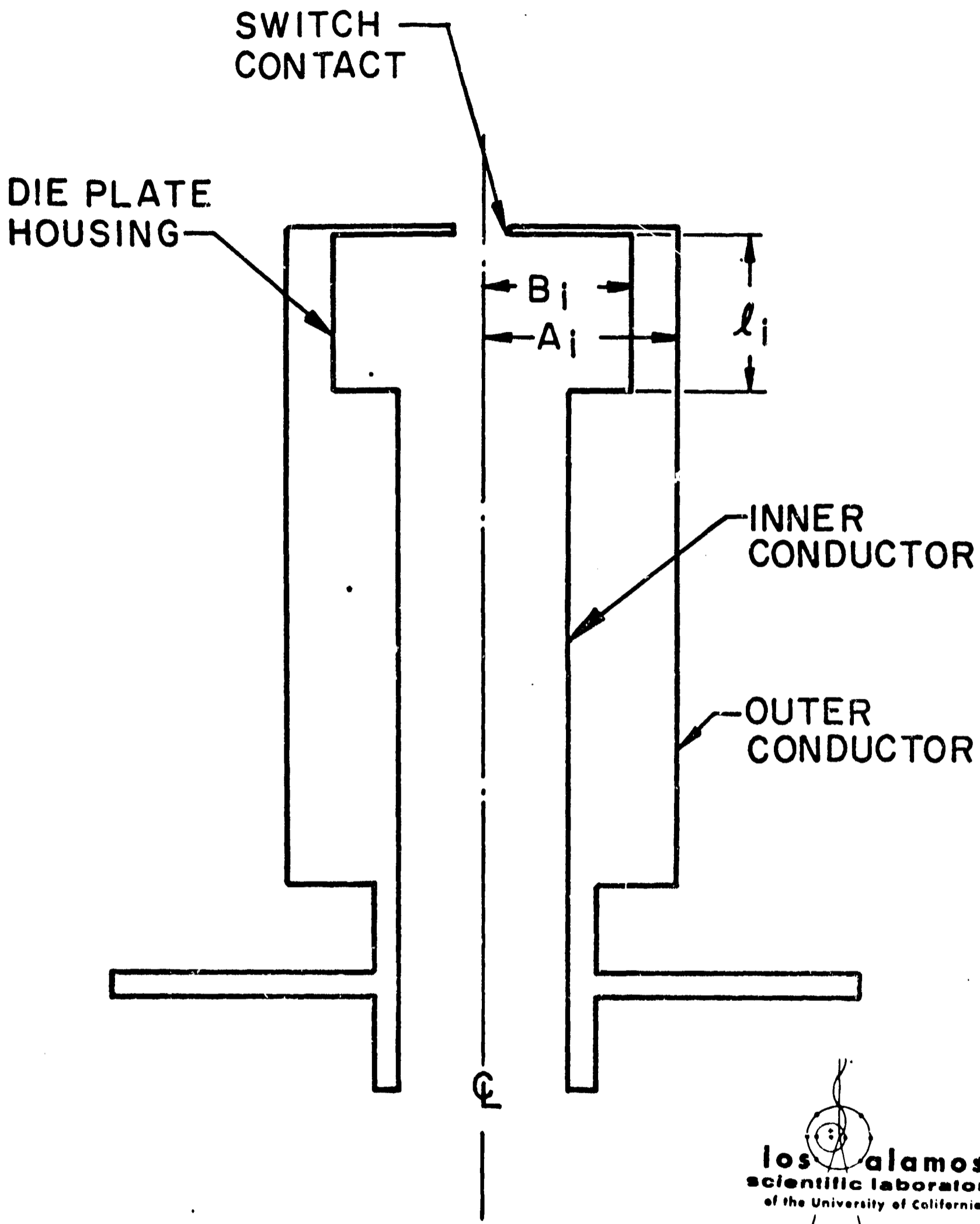
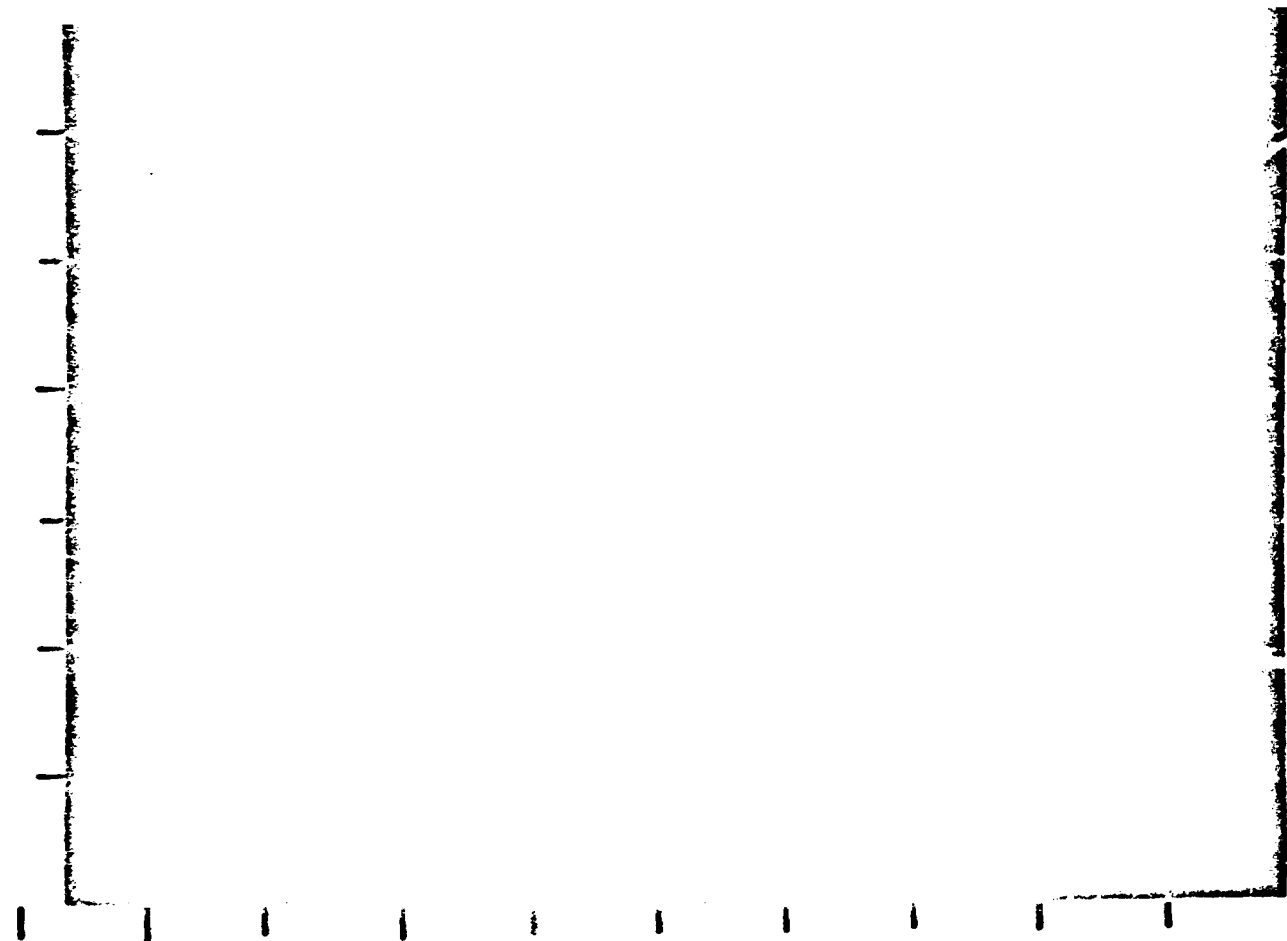

Fig 5

154 kA / DIV

77 kA / DIV



CROWBAR CURRENT

TOP TRACE 10 μ SEC / DIV

BOTTOM TRACE 100 μ SEC / DIV

fig. 6



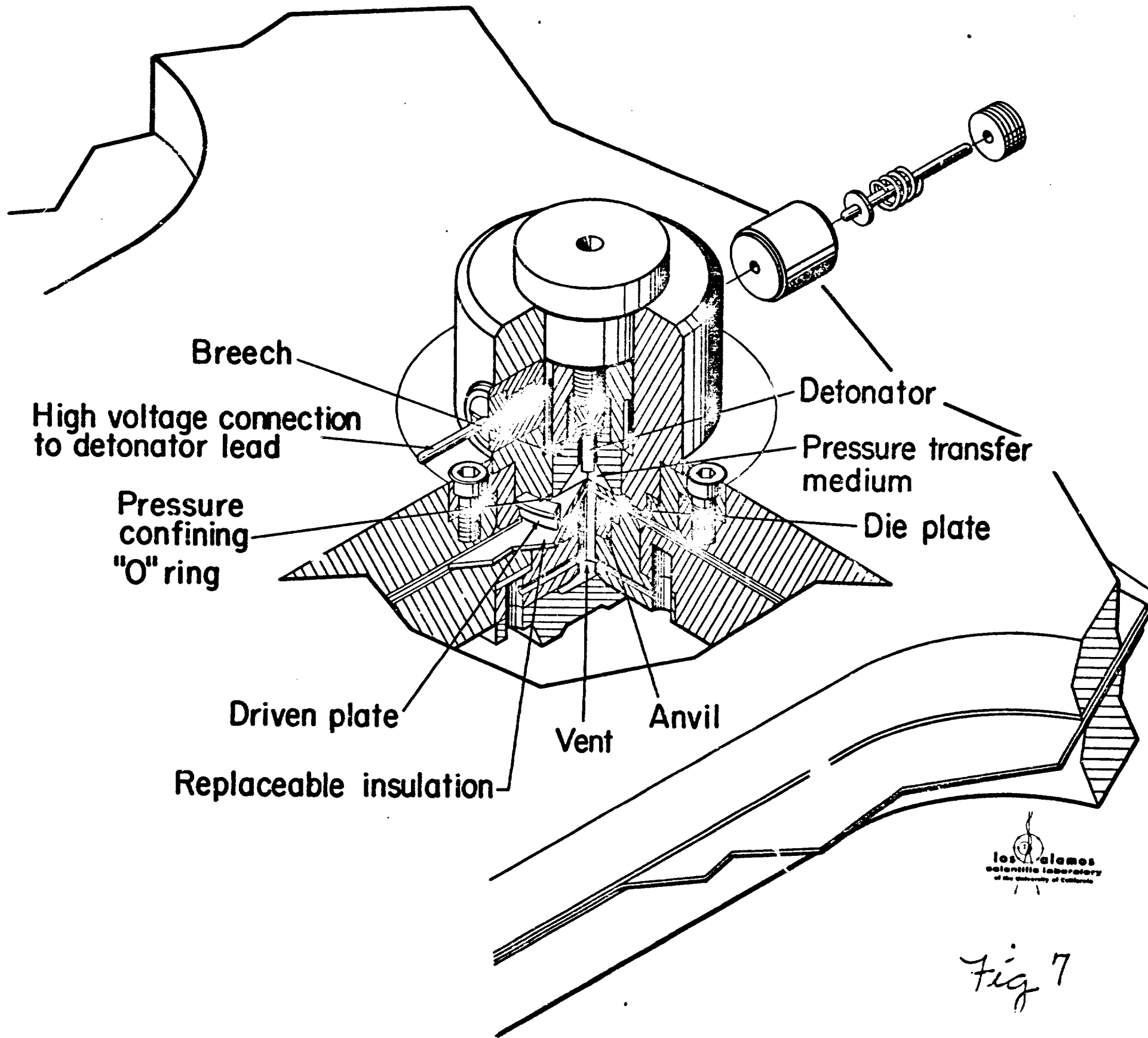

BANK CURRENT

PINCH CURRENT
180 kA / DIV

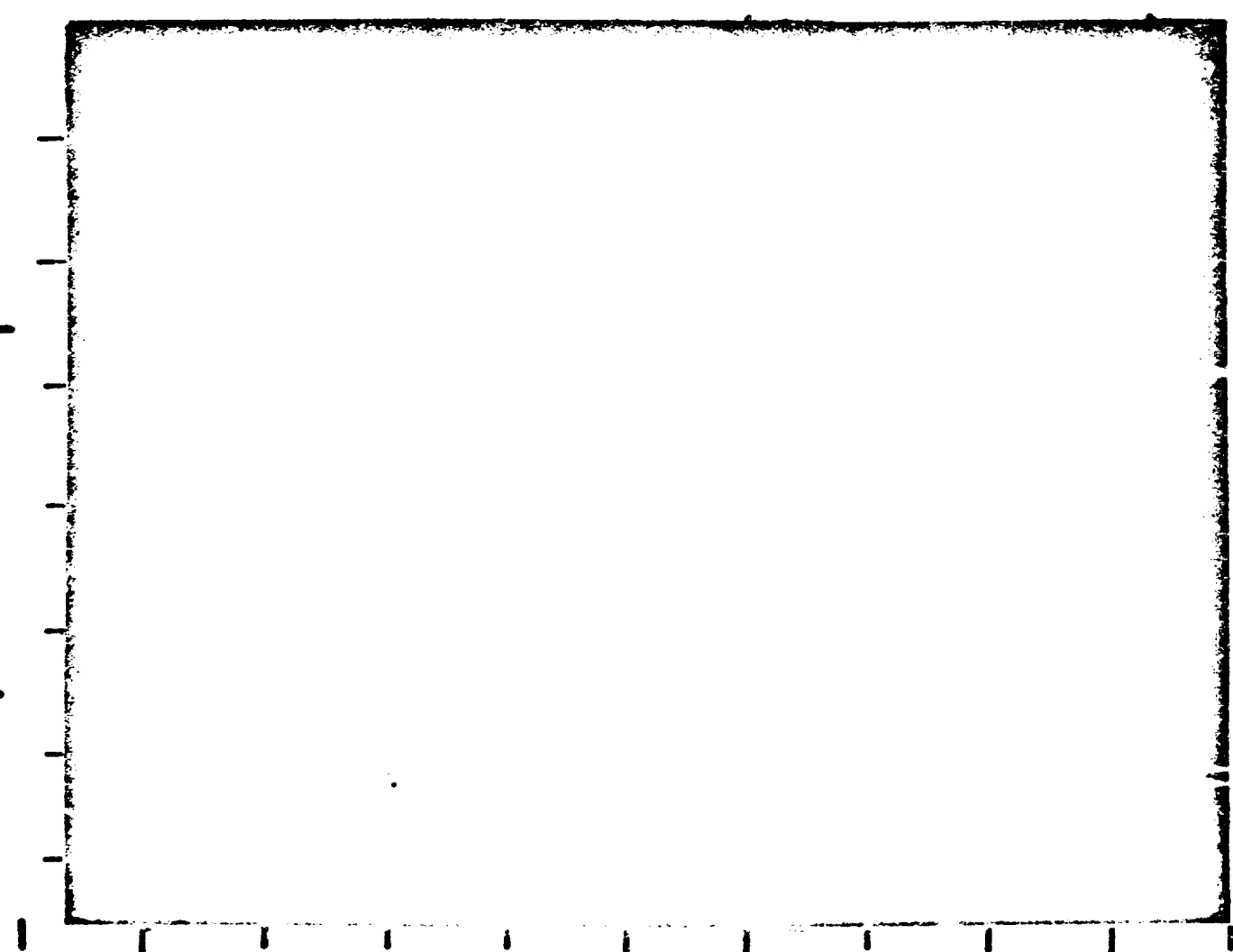

200 μ SEC / DIV

fig-8

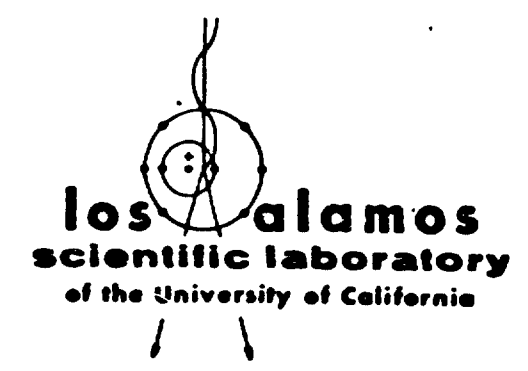

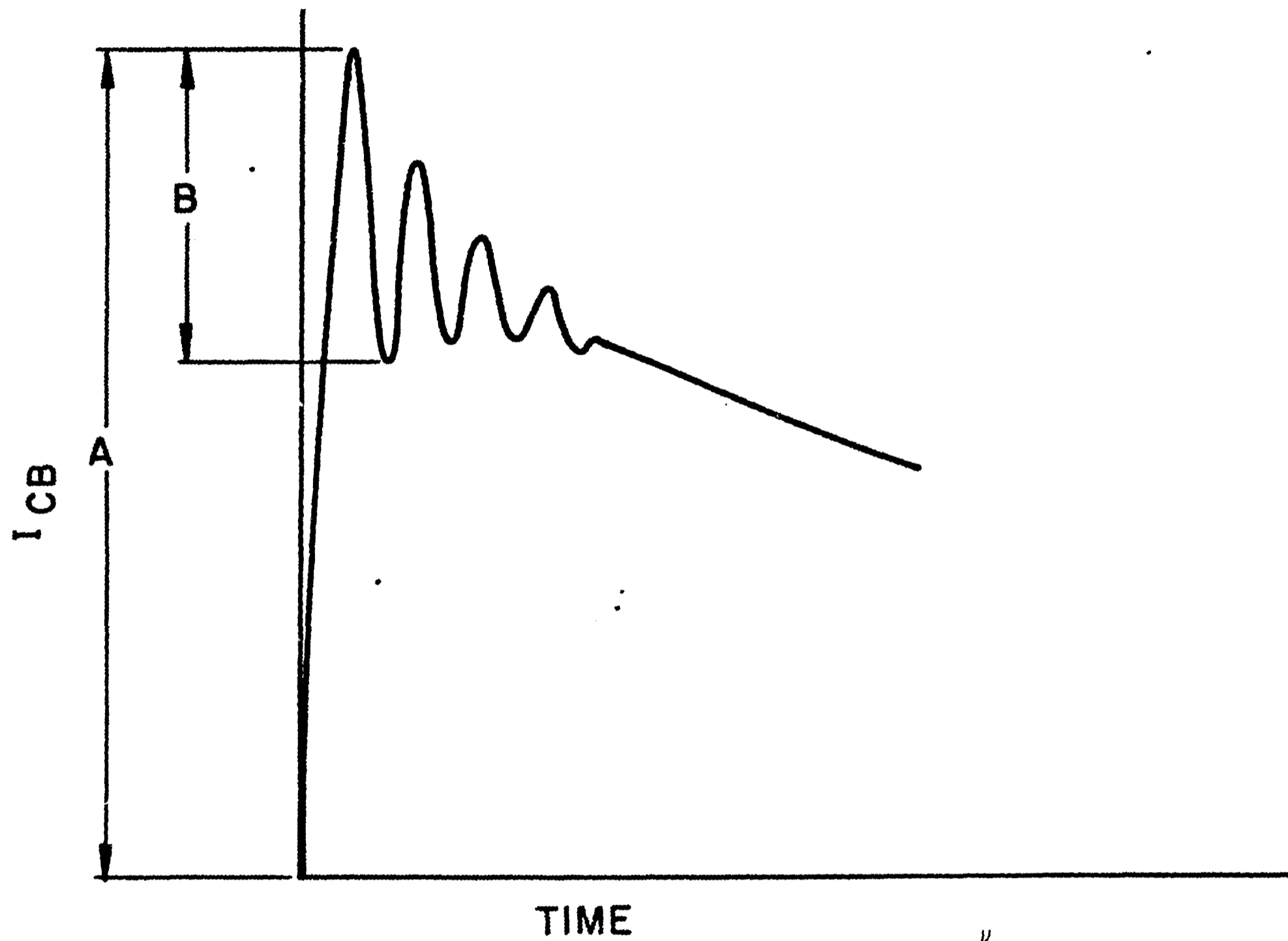



los alamos
scientific laboratory
of the University of California

Fig 9

CROWBAR CURRENT
188 kA/DIV

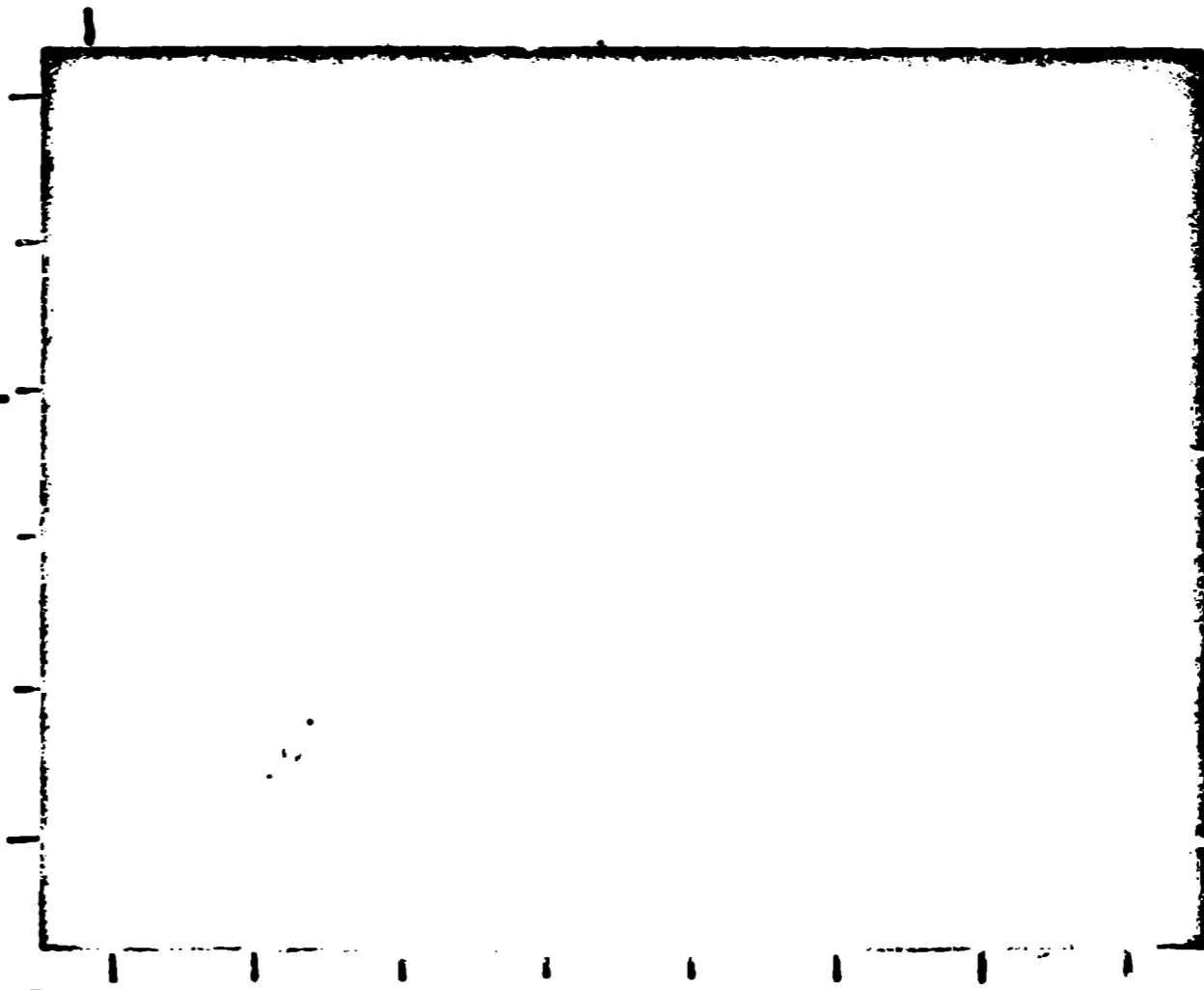
CROWBAR VOLTAGE



500 μ SEC/DIV



Fig 10

SWITCH H.V. TEST
12 kV / DIV

BRIDGE WIRE
CURRENT

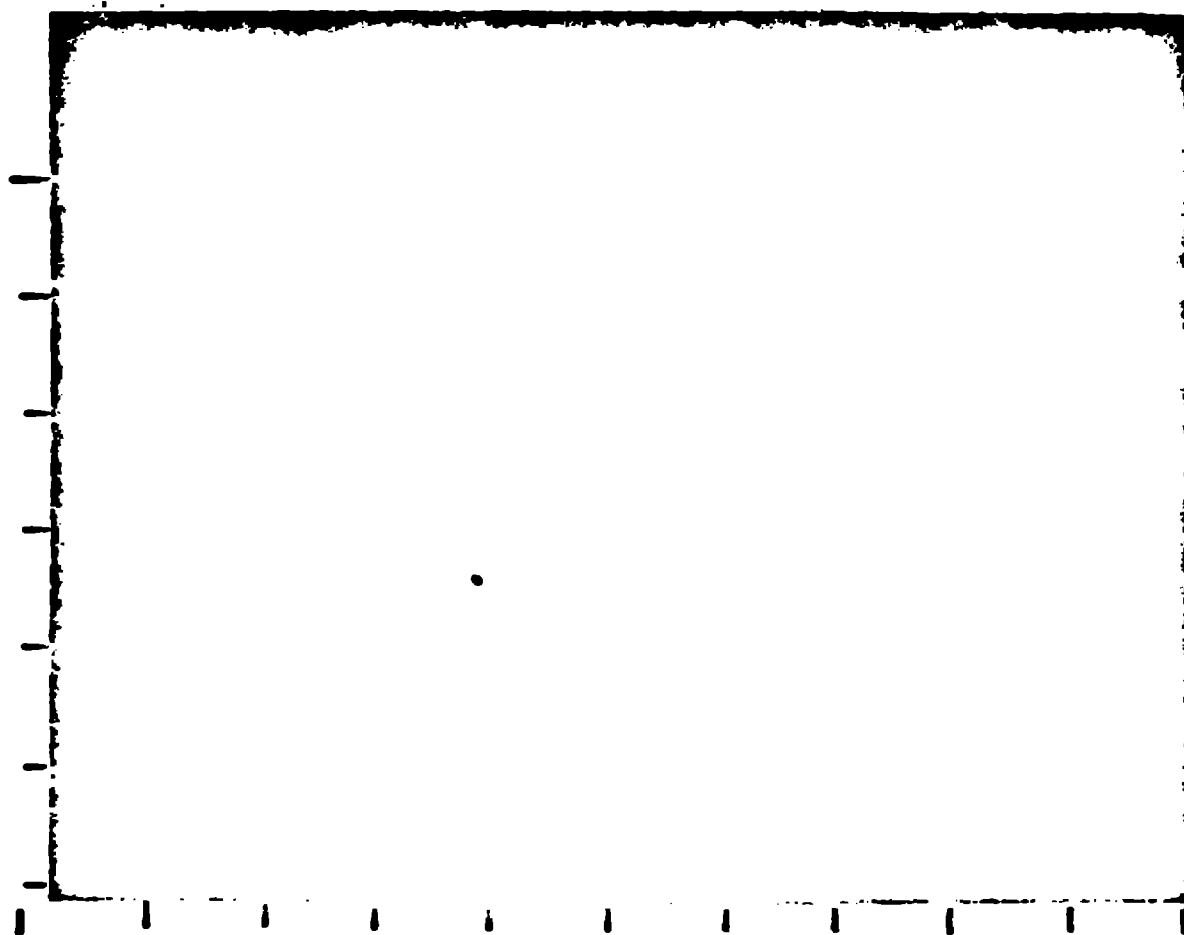

5 μ SEC / DIV.

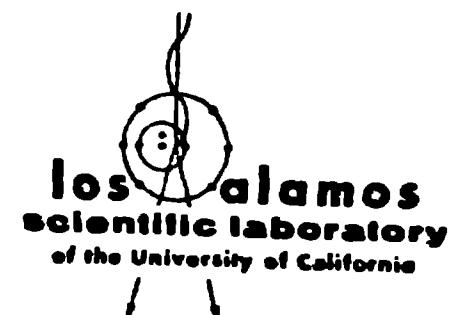

Fig 11

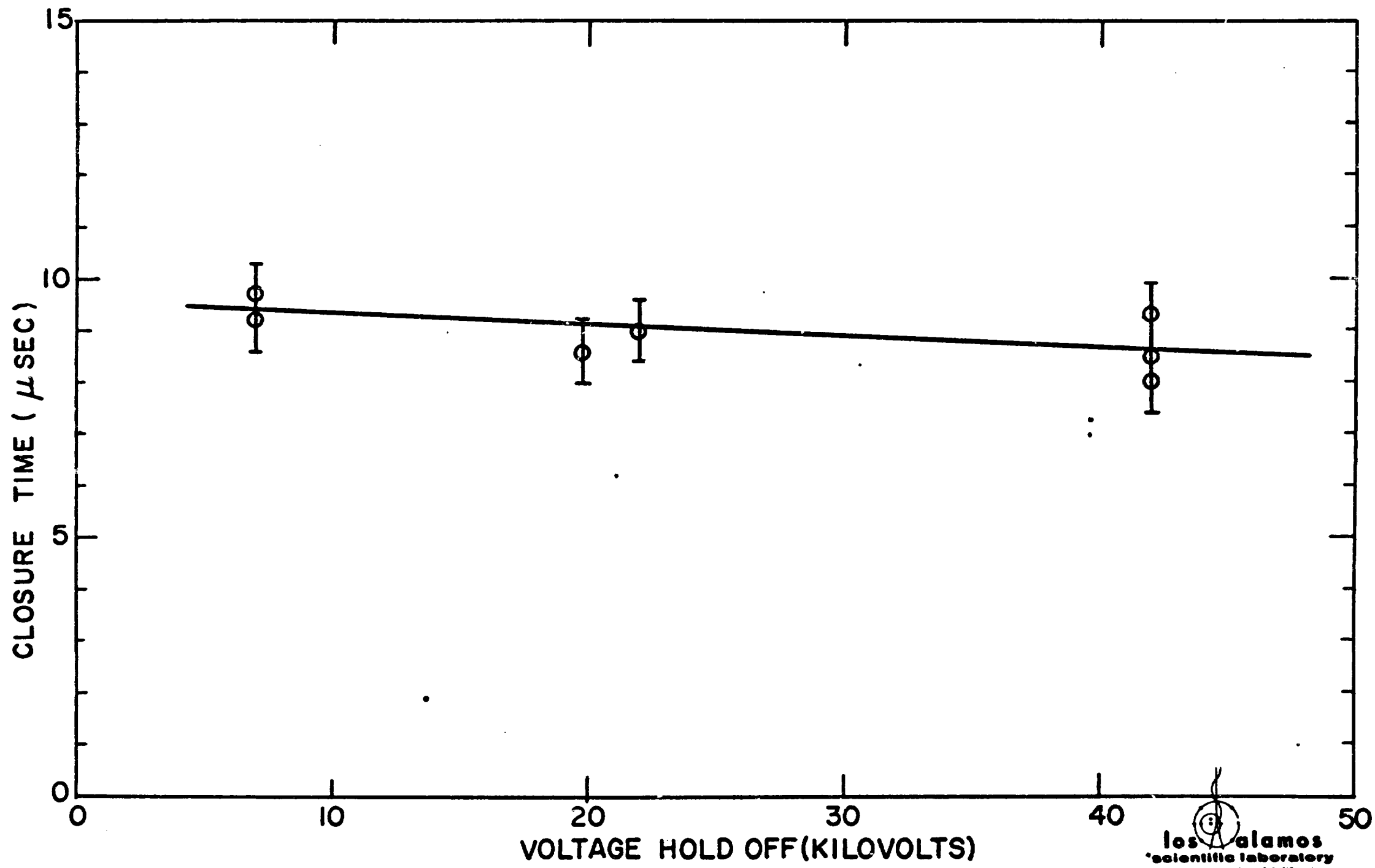

Fig 12